

# Interstate Diesel

## Injector Core Identification Guide





# Interstate Diesel

These items are applicable to ALL core returns:

1. All cores must be returned freight prepaid to:

**Interstate-McBee  
4901 Lakeside Ave.  
Cleveland, OH. 44114  
Attn: Core Return Department**

International returns must be sent through customer's chosen freight forwarder as "DDP" (Delivery Duty Paid), including customs clearance paid and arrangement for pre-paid delivery all the way to the address above.

2. Cores must be received by Interstate-McBee no later than 60 days from date of invoice. Credit will not be issued for cores received after 60 days.
3. Only cores with the same group or core code classification as the exchange unit ordered will be acceptable (see <https://interstate-mcbee.com/document-library> for Core Acceptance Catalog).
4. A packing list must be included with all core returns. The packing list must have company name, address, contact name and phone number plus detail quantity and identification of cores by one or more of the following:
  - a. Core code or core group
  - b. Part number
  - c. Interstate-McBee Invoice or Order number
5. If no invoice or order number is referenced on packing slip, credit will be issued to oldest outstanding invoice with corresponding exchange unit.
6. Core must be returned in protective packaging to prevent damage which may be caused during transportation.
7. Core must be in "off engine" condition as it was when originally removed from the engine.
8. Cores must be complete and cannot have been disassembled since being removed from the engine.
9. Cores damaged by non-operational causes such as rough handling, improper removal from the engine, fire or improper protection during storage will not be accepted.
10. Electronic injectors with broken stator terminals will not be accepted (see #9 above) unless otherwise noted in the Core Acceptance Catalog.
11. Light flash rust is acceptable, but heavy rust and/or pitting due to improper protection during storage is not acceptable.
12. Credit will be given only for cores owed. Additional cores received will be scrapped or returned at customer's expense. IMCB will not "Bank" excess cores.
13. The customer will be contacted by Interstate-McBee regarding any discrepancy and given 10 days to respond.

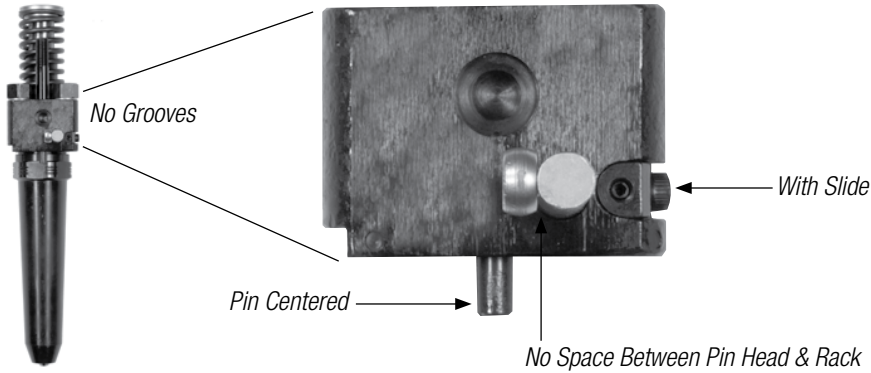
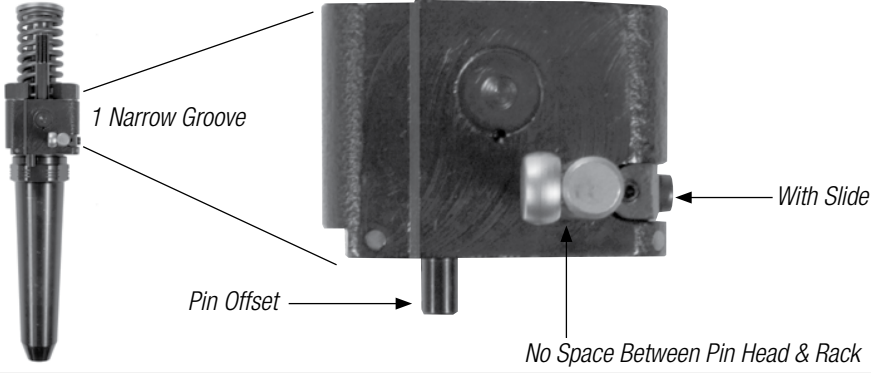
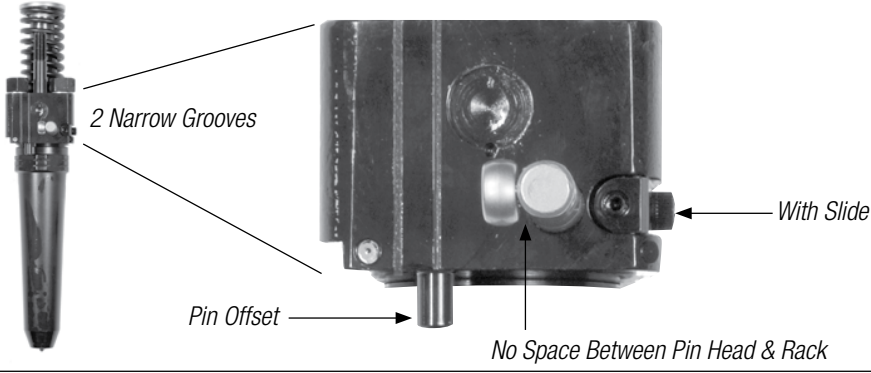
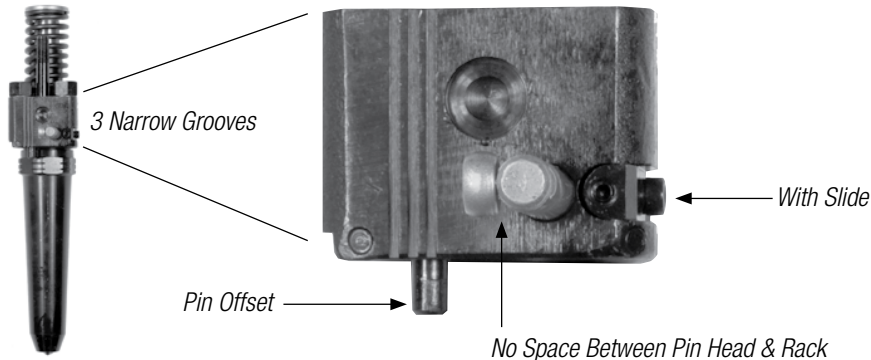

# Acceptable Mechanical Injector Cores

Core No. / Body Description	Injector Part Numbers
<p><b>C-EMDNO</b> No Grooves, With Slide</p> 	<p>5229295, 5229500, 8478049, 9081163, 40078996, 40079003, 40083527, 40083534, 40084722, 40084726, 40129258, 4991632</p>
<p><b>C-EMD1N</b> 1 Narrow Groove With Slide</p> 	<p>5229200, 5229290, 5229510, 8478045, 8478048, 9081164, 40078993, 40078995, 40079004, 40083524, 40083526, 40083535, 40084719, 40084721, 40084727, 40100567, 40100740, 4991629, 4991635</p>
<p><b>C-EMD2N</b> 2 Narrow Grooves With Slide</p> 	<p>5229305, 5229310, 8478050, 8478051, 40078997, 40078998, 40083528, 40083529</p>
<p><b>C-EMD3N</b> 3 Narrow Grooves With Slide</p> 	<p>5229250, 5229315, 8478046, 8478052, 40078994, 40078999, 40084720, 40100568, 40100741, 4992064</p>

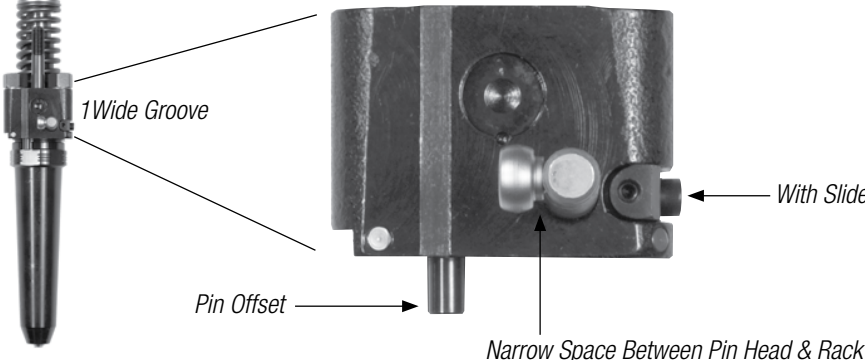
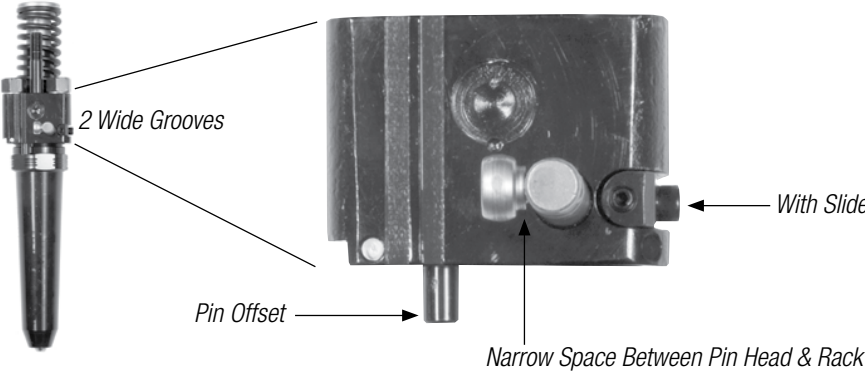
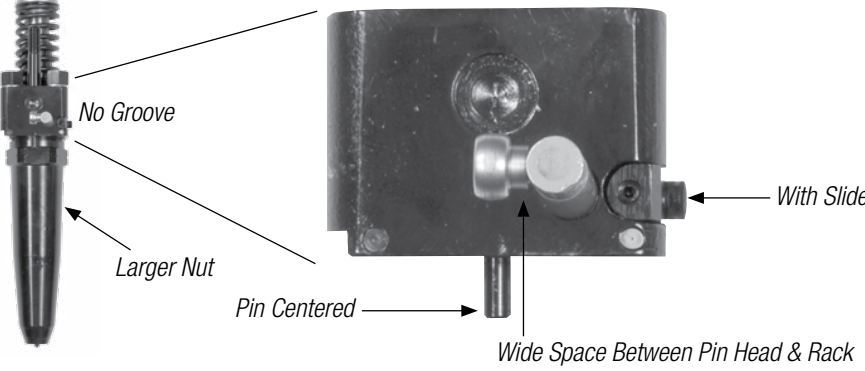

# Acceptable Mechanical Injector Cores

Core No. / Body Description	Injector Part Numbers
<p><b>C-EMD1W</b> 1 Wide Groove, With Slide</p> 	<p>4991017, 5229320, 5229325, 5229335, 8478053, 8478054, 8478055, 40079000, 40079001, 40079002, 40083531, 40083532, 40083533, 40084723, 40084724, 40084725, 40100569, 40100742</p>
<p><b>C-EMD2W</b> 2 Wide Grooves, With Slide</p> 	<p>5226150, 5226210, 5226430, 5226470, 5226775, 5226785, 5229710, 5235585, 5236671, 9333858, 9561950, 9576569, 40043489, 40078986, 40078987, 40078988, 40078990, 40079005, 40079006, 40079009, 40080872, 40083516, 40083518, 40083519, 40083520, 40083523, 40083536, 40083539, 40084713, 40084714, 40084715, 40084718, 40084728, 40084731, 40098027, 40099335, 40100501, 40100570, 40100743</p>
<p><b>C-EMD710</b> No Groove, With Slide</p> 	<p>5226700, 5227000, 5227285, 5235595, 9565086, 40027607, 40028663, 40044488, 40077234, 40077235, 40078991, 40079007, 40083521, 40083537, 40083538, 40083540, 40084717, 40084729, 40084730, 40084732, 40095069, 40103324, 40111736, 40112504</p>



# Unacceptable Mechanical Injector Cores

\*except for conversions as noted.

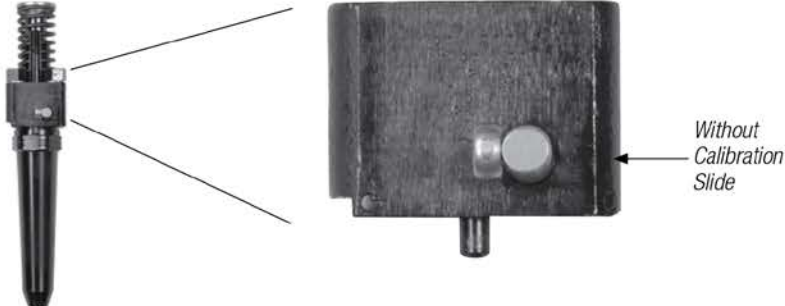
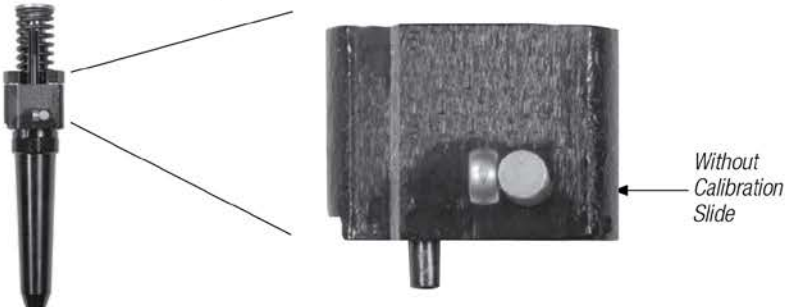
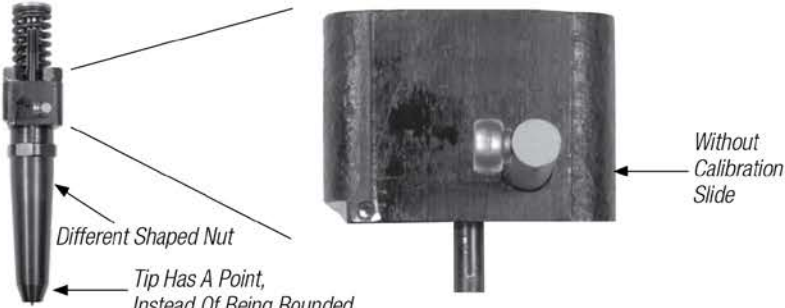
Core No. / Body Description	Injector Part Numbers
<p><b>C-E8565</b> No Groove, Without Slide</p> 	<p>5228565 8296456 8477972</p>
<p><b>C-E8540</b> 1 Narrow Groove, Without Slide</p> 	<p>5228540</p>
<p><b>Cleveland Diesel / Spherical Valve</b> No Groove, Without Slide</p> 	<p>5228190, 5227326</p>

## C-EUI Injector Cores

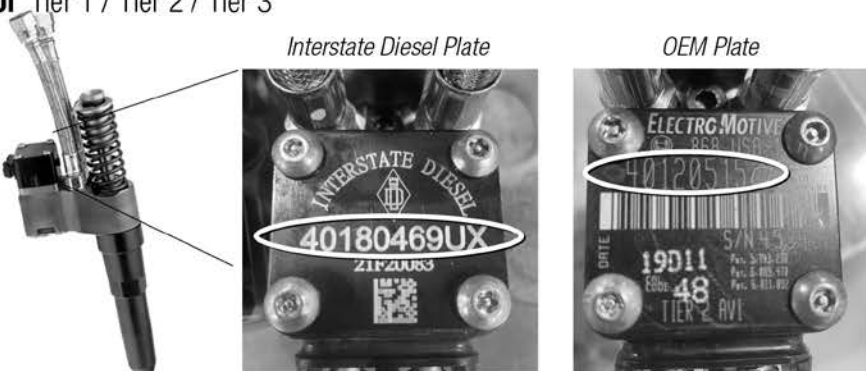
<p><b>C-EUI</b> Tier 1 / Tier 2 / Tier 3</p> 	<p><b>ACCEPTABLE:</b></p> <p>40085394, 40087510, 40112933, 40112941, 40120514, 40120515, 40154730, 40154734, 40180469, 40180469-UX</p> <p><b>NOT ACCEPTABLE:</b></p> <p>40085392, 40087509</p>
---	--





# Reduce Emissions. Save Fuel. Achieve Goals.

**WV Central/Durbin & Greenbrier Valley Railroad's mission statement:** *"Provide a new level of dedication and the best possible rail service for meeting the demands of today's rail shippers".*

John Smith, President of the WVC knows that in order to achieve the goals of his mission statement, he needs to keep close track of all his expenses. Ask him what are his monthly fuel costs and he can tell you since he writes the checks each month. So when his fuel distributor delivered a bad load of fuel which caused multiple fuel injector failures, he knew an expected expense was coming his way.

Roger Phillips, CMO of the WVC made the recommendation to John to replace all the injectors in his fleet of four locomotives and suggested the Interstate Ecotip® Green Tag injector. Interstate Diesel is the world's leader for EMD injectors and exclusive supplier to Electro-Motive Diesel for all mechanical injectors so quality and performance were guaranteed.

After installing the Ecotip Green Tag into his entire fleet, John noticed something unexpected during his check writing days. His fuel costs had gone down, way down. "After replacing the injectors with Interstate's Ecotips, our fuel bills dropped by over 10%. We didn't make any other changes and our business remained constant so the fuel savings are definitely the result of using doing a complete change-out with Ecotip injectors".

The patented Ecotip injector is available exclusively from Interstate-McBee and has been helping railroads like the WVC/Durbin & Greenbrier Valley achieve their mission statement goals every day. Lower emissions, fuel savings and achieving goals are all possible with the help of full set of Ecotip Green Tag injectors from Interstate-McBee.

"After replacing the injectors with Interstate's Ecotips, our fuel bills dropped by over 10%. We didn't make any other changes and our business remained constant so the fuel savings are definitely the result of using doing a complete change-out with Ecotip injectors."

— John Smith, President,  
WV Central / Durbin & Greenbrier Valley RR



**ECOTIP® Superstack** used in multiple applications



**Serving the Railroad Industry with Quality Since 1947.**

## Interstate Diesel

4901 Lakeside Ave., Cleveland, OH 44114-3996

Toll Free: (800) 321-4234 Fax: (216) 706-5010

[www.interstate-mcbee.com/emd/emd.htm](http://www.interstate-mcbee.com/emd/emd.htm)



"Crowley Liner Service installed ECOTIP® Superstack green tag injectors in the tug Sentry...in May 2004 to initiate a test of the injector's ability to save fuel. The vessel was operated during the entire testing period as we would any of the vessels in this service. The average reduction in fuel consumption over the life of the testing period was 3.01%. Since we realized reduced fuel consumption during this test, all of the engines in our line haul service have been changed to the ECOTIP® injectors."

— Crowley Liner Services, Inc.,  
Engineering Department

"During the past two years, the short line has taken several measures to lower emissions and fuel usage. Tacoma Rail began using Interstate-McBee L.L.C.'s EcoTip® Superstack fuel injectors, which have reduced particulate matter emissions 44 percent and provided 3 percent in fuel savings."

— Tacoma Rail, as seen in  
Progressive Railroading

"At Tacoma Rail, we've been able to track fuel savings for our idling locomotives. We also aspire to 'green up' addition."  
— Phil Hogman, Tacoma Rail,  
Mechanical Department Supervisor



Obtain up to a 3% fuel savings in most applications and reduce emissions.



Find our ECOTIP® Superstack injector in Electro-Motive Diesel Certified 710 Tier 0 engines.



Find our ECOTIP® Ultrastack injector in Electro-Motive Diesel Certified 645 Tier 0 engines.



Customize an injector to fit your specific needs. Use our ECOTIP® special technology to help you with low idle and special applications.



Find our ECOTIP® injectors in the Electro-Motive Diesel Certified Tier 0+, 1042 Marine, and Marine 1042+ Emission Kits.



## Interstate Diesel

Ship all cores to:

**Interstate-McBee**

4901 Lakeside Avenue

Cleveland, Ohio 44114 U.S.A

Toll Free 800-321-4234

Fax: 216-706-5010

[www.interstate-mcbee.com](http://www.interstate-mcbee.com)